

RYOBI®

AP13AK

PLANER THICKNESSER WITH ANTI KICKBACK OWNER'S OPERATION MANUAL

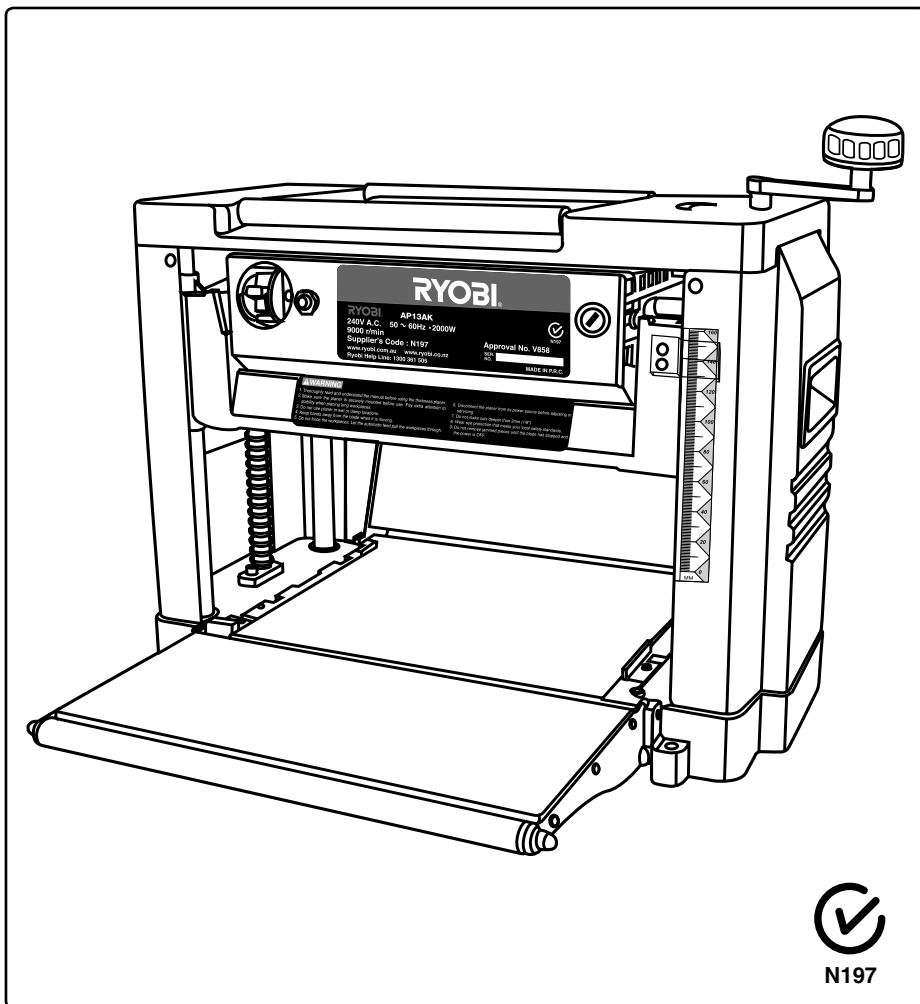

N197

TABLE OF CONTENTS

■ Table of Contents	1
■ Specifications	1
■ Rules for Safe Operation	2-4
■ Loose Parts List	4
■ Operation	5
■ Adjustment	6-9
■ Maintenance	10
■ Troubleshooting	11

PRODUCT SPECIFICATIONS

• Input	2000 watt
• No Load Speed	9000 R.P.M.
• Min Planing Length	127 mm
• Max Planing Width.....	318 mm
• Planing Height	5 - 153 mm
• Depth Per Pass	3 mm
• Feeding Speed	8m / min
• Binder	48mm with 2 blades, 9000 R.P.M. ie 18000 C.P.M.
• Weight	32 - 30.5 kg



**Look for this symbol to point out important safety precautions. It means attention!!!
Your safety is involved.**

RULES FOR SAFE OPERATION

The purpose of safety rules is to attract your attention to possible dangers. The safety symbols and the explanations with them, require your careful attention and understanding. The safety warnings by themselves do not eliminate any danger. The instruction or warnings they give are not substitutes for proper accident prevention measures.



SAFETY ALERT SYMBOL. Indicates caution or warning. May be used in conjunction with other symbols or pictures.

WARNING: Failure to obey a safety warning can result in serious injury to yourself or to others. Always follow the safety precautions to reduce the risk of fire, electric shock and personal injury.

DOUBLE INSULATION

Double insulation is a concept in safety in electric power tools, which eliminates the need for earth grounding. Whenever there is electric current in the tool there are two complete sets of insulation to protect the user. All exposed metal parts are isolated from the internal metal motor components with protecting insulation.

WARNING: The double insulated system is intended to protect the user from shock resulting from a break in the tool's internal wiring. Observe all normal safety precautions related to avoiding electrical shock.

IMPORTANT: Servicing of a tool with double insulation requires extreme care and knowledge of the system and should be performed only by a qualified service technician. For service we suggest you return the tool to your nearest Ryobi Authorised Service Centre for repair. When servicing, use only identical Ryobi replacement parts.

WARNING: Do not attempt to operate this tool until you have read thoroughly and completely understood the safety rules, etc. contained in this manual. Failure to comply can result in accidents involving fire, electric shock or serious personal injury. Save owners manual and review frequently for continual safe operation and for instructing others who may use this tool.



The operation of any tool can result in foreign objects being thrown into your eyes, which can result in severe eye damage. Before beginning power tool operation, always wear safety goggles or safety glasses with side shields and a full face shield when needed. We recommend Wide Vision Safety Mask for use over eye glasses or standard safety glasses with side shields.

- 1. KNOW YOUR POWER TOOL.** Read owners manual carefully. Learn its applications and limitations as well as the specific potential hazards related to this tool.
- 2. GUARD AGAINST ELECTRICAL SHOCK BY PREVENTING BODY CONTACT WITH GROUNDED SURFACES.**
For example, pipes, radiators, ranges, refrigerator enclosures.
- 3. KEEP WORK AREA CLEAN.** Cluttered areas and benches invite accidents.
- 4. AVOID DANGEROUS ENVIRONMENT.** Don't use power tools in damp or wet locations or expose to rain. Keep work area well lit.
- 5. KEEP CHILDREN AND VISITORS AWAY.** Visitors should wear safety glasses and be kept a safe distance from work area. Do not let visitors contact tool or extension cord.

- 6. STORE IDLE TOOLS.** When not in use, tools should be stored in a dry and high or locked-up place, out of reach of children.
- 7. DON'T FORCE TOOL.** It will do the job better and safer at the rate at which it was designed.
- 8. USE RIGHT TOOL.** Don't force a small tool or attachment to do the job of a heavy duty tool. Don't use tool for any purpose not intended.
- 9. DRESS PROPERLY.** Do not wear loose clothing or jewellery. They can be caught in moving parts. Rubber gloves and non-skid footwear are recommended when working outdoors. Also wear protective hair covering to contain long hair.
- 10. ALWAYS WEAR SAFETY GLASSES.** Everyday eyeglasses have only impact resistant lenses, they are not safety glasses.
- 11. PROTECT YOUR LUNGS.** Wear a dust mask if operation is dusty.
- 12. PROTECT YOUR HEARING.** Wear hearing protection during extended periods of operation.
- 13. DON'T OVERREACH.** Keep proper footing and balance at all times. Do not use tool on a ladder or unstable support. Secure tools when working at elevated levels.
- 14. MAINTAIN TOOLS WITH CARE.** Keep tools sharp and clean for better and safer performance. Follow instructions for lubricating and changing accessories.
- 15. DISCONNECT TOOLS.** When not in use, before servicing, or when changing attachments, blades, bits, cutters, etc. all tools should be disconnected.
- 16. REMOVE ADJUSTING KEYS AND WRENCHES.** Before turning it on, Form a habit of checking to see that keys and adjusting wrenches are removed from tool.
- 17. NEVER USE IN AN EXPLOSIVE ATMOSPHERE.** Normal sparking of the motor could ignite fumes.
- 18. KEEP HANDLES DRY, CLEAN AND FREE FROM OIL AND GREASE.** Always use a clean cloth when cleaning. Never use brake fluids, gasoline, petroleum based products, or any strong solvents to clean your tool.
- 19. STAY ALERT AND EXERCISE CONTROL.** Watch what you are doing and use common sense. Do not operate tool when you are tired. Do not rush.
- 20. CHECK DAMAGED PARTS.** Before further use of the tool, a guard or any other part that is damaged should be carefully checked to determine that it will operate properly and perform its intended function. Check for alignment of moving parts, binding of moving parts, breakage of parts and any other conditions that may affect its operation. A guard or any other part that is damaged should be properly repaired or replaced by an authorised service centre.
- 21. DO NOT USE TOOL IF SWITCH DOES NOT TURN IT ON AND OFF.** Have defective switches replaced by authorised service centre.
- 22. DO NOT OPERATE THIS TOOL WHILE UNDER THE INFLUENCE OF DRUGS, ALCOHOL OR ANY MEDICATION.**
- 23. SUPPLY CORD.** If the supply cord is damaged, it must be replaced by the manufacturer or its service agent or similarly qualified person in order to avoid a hazard.

Due to Ryobi's continued product refinement policy, product features and specifications can and will change without notice. Check current features and specifications with your Ryobi retailer.

SAVE THESE INSTRUCTIONS

RULES FOR SAFE OPERATION

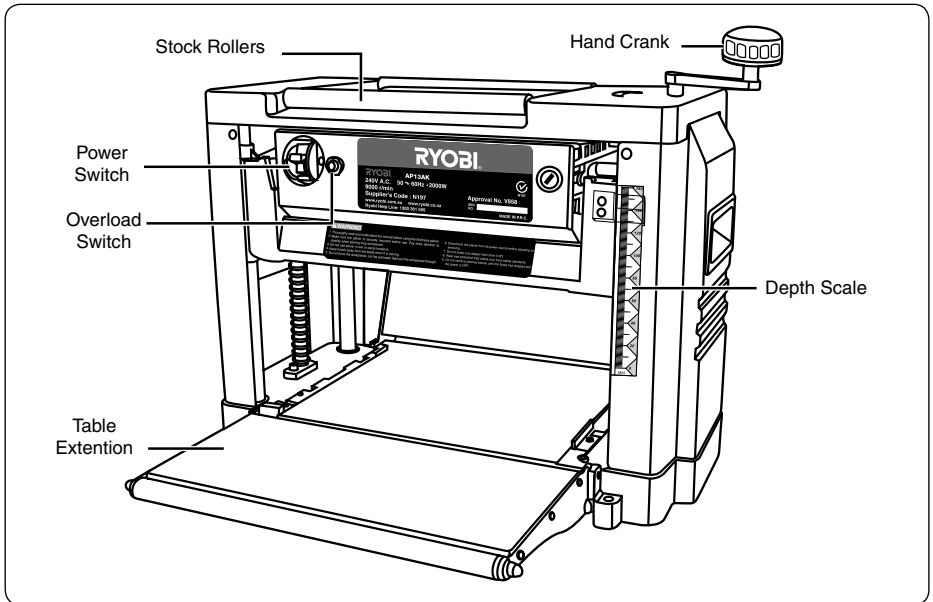

- Always wear eye protection when operating the machine.
- Check to make sure all holding screws are tight before starting machine.
- Always stop the motor and disconnect from power source before making any adjustments.
- Be sure all guards are in place before operation.
- Read owner's manual thoroughly and familiarise yourself with the machine before operation.
- Do not force work through the machine. Allow the planer to apply the proper feed rate.
- Check feed rollers occasionally to be sure sawdust and chips are not lodged between any components. If rollers are not seated firmly, the feed rolls will not hold timber firmly against the bed, allowing kickback.
- Only plane wood boards.
- Use sound timber, with no loose knots and as few tight knots as possible.
- Never stand directly in line with either the infeed or outfeed sides. Always stand off to one side of the machine.
- Make sure the workpiece is free of nails, screws, stones and other foreign objects which could damage the blades.
- Make sure the blades are attached correctly as described in the instructions.
- Use caution when handling the blades and cutterhead assembly. The blades are sharp and can easily cut your hand.
- Allow the cutterhead to reach full speed before using.

RULES FOR SAFE OPERATION

Anti-Kickback Pawls

- Device which, when properly installed and maintained, is designed to stop the workpiece from being kicked back toward the front of the Blade during a Planer operation.

- Always hold your workpiece firmly with both hands, keep your body in a balanced position to be ready to resist kickback. Never stand directly in line with timber.

Avoiding kickback

- Always use the correct Blade depth setting.
Inspect the work for knots or nails before beginning a cut. Knock out any loose knots with a hammer, never cut into a loose knot or nail.
- Always use clear, sharp, and properly-set blades.
- Never make planer with dull blades.
- To avoid pinching the Blade, support the work properly before beginning a planer operation.
- When making a planer operation, use steady, even pressure, never force to plane.
- Do not plane wet or warped timber.

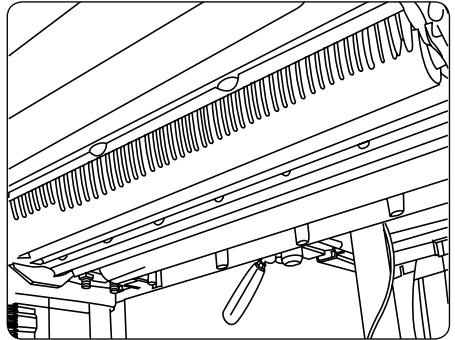

LOOSE PARTS LIST

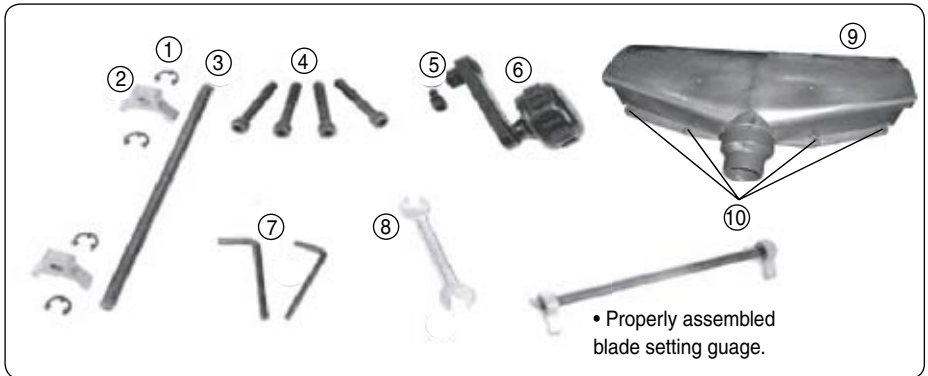

1) "C" Circlip	4 pieces
2) Blade Setting Guide	2 pieces
3) Blade Setting Gauge Shaft	1 piece
4) Base Lock Screw8mm x 50(L).....	4 pieces
5) Elevation Knob Lock Screw6mm x 15(L).....	1 piece
6) Cutterhead Raising Hand Crank	1 piece
7) Allen Wrenches	4 & 5mm
8) Open End Wrench8 x 10.....	1 piece
9) Dust Chute.....	1 piece
10) Philip Screws.....	4 pieces

MOVING THE PLANER (Fig. 1)

- The planer can be carried using the handles on either side of the frame. Make sure the table extensions are closed before moving the planer.

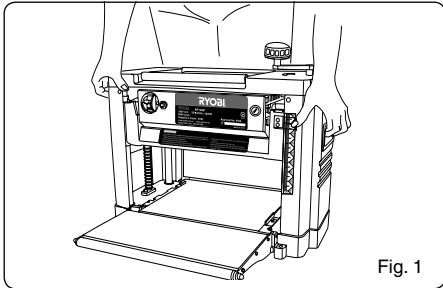

MOUNTING THE PLANER ONTO THE WOOD BASE (Fig. 2a&2b)

- When the planer is not mounted on a planer stand, it is suggested that it be mounted onto two pieces of timber. This will ensure maximum stability.
- Choose two pieces of wood according to the sizes shown on the figure below. Mount the planer onto the wood surface.
- Use four long, furnished screws to mount the planer base onto the wood (Fig. 2a)

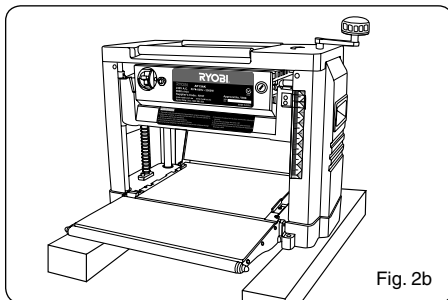
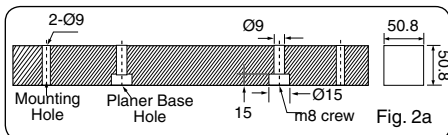

STOCK ROLLERS (Fig. 3)

- Two rollers are built on top of the planer, providing convenient handling of stock for consecutive cutting operations. Stock placed on the top of the machine can be easily pulled to the operator for planing.

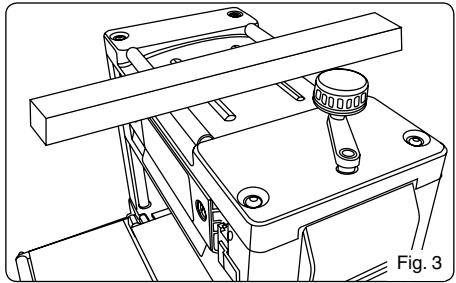

ON / OFF SWITCH (Fig. 4)

- Your Planer Thicknesser has a rocker style switch with a removable locking key to prevent unauthorised use. If you intend to be away from the machine for a long period of time and there is any chance of its use by others, especially children, remove the locking key with the switch in the OFF position. Store the locking key in a safe, inconspicuous place in your workshop. To turn the planer on, insert the locking key and turn the switch to the ON position. The planer will then be operable. To turn the planer off, turn the switch to the OFF position. (Fig. 4)

⚠ WARNING:

Always be sure the switch is in the off position before connecting the planer to the power source.

CIRCUIT OVERLOAD SWITCH

- The machine is provided with an overload switch for overload protection. If an overload occurs, the switch will pop out. If this happens, wait several minutes and press the switch to reset the machine. (Fig. 4)

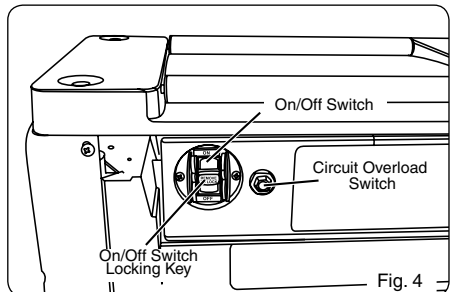

ADJUST DEPTH OF CUT (Fig. 5)

⚠ WARNING:

Never plane more than 3mm in one pass and never attempt to plane a board under 127mm (5") in length. Always wear a protective face shield.

- To adjust the depth of cut, turn the cutterhead-raising hand crank in the direction marked on top of the planer. The depth of cut adjustment can be read from the depth scale. The adjustment gradation is 2mm per revolution of the hand crank. (Fig. 5)
- Always start your work by making a light planing cut. The depth of cut on subsequent passes may be increased by up to 3mm, but remember that a light cut creates a finer finish than a heavier cut.
- The thickness of timber running through the planer is controlled by the distance you adjust the cutting blade from the table.
 - Do not plane timber which is less than 5mm thick.
 - Do not plane timber which is thicker than 153mm (6").

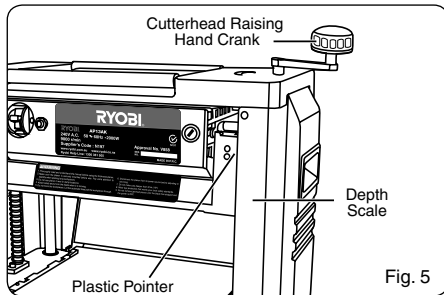

Fig. 5

- When you have properly adjusted the depth of cut scale, test your reading by planing a piece of scrap timber. After planing, measure the planed thickness and double check it against the scale reading. The two measurements should be the same, re-adjust your depth of cut scale to read the planed thickness if necessary.

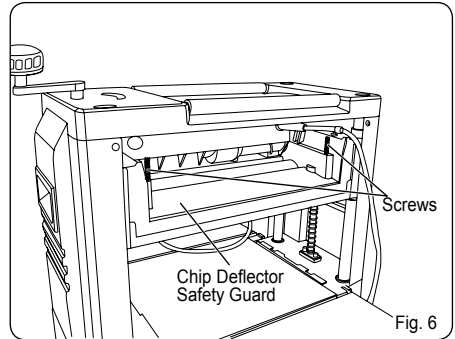

Fig. 6

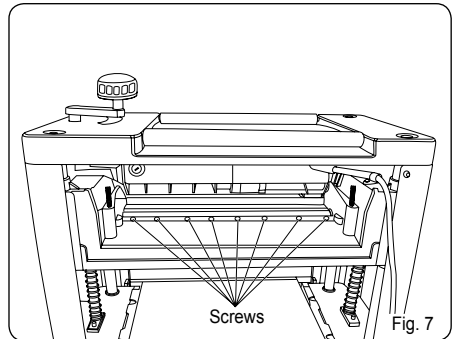

Fig. 7

ADJUSTING THE DEPTH OF CUT SCALE (Fig 6&7)

For safe operation of your planer, it is very important that the depth of cut scale is read accurately. To adjust the depth of cut scale, follow the steps outlined below:

- Try to feed a board for planing. Compare the measured thickness of the board to the reading on the depth of cut scale.
- If the reading on the depth of cut scale is incorrect, loosen the screw which tightens the plastic pointer and adjust accordingly (Fig. 5)

REMOVING THE PLANER BLADES (Fig. 7a)

To remove the planer blades, follow the steps outlined below:

WARNING:

Unplug your planer from the power source before removing the planer blades.

- Remove the chip guard by removing the wing nut on each side.
- Loosen the lock bar (B) and blade by turning the lock screws (A) clockwise. The blades are spring loaded, and will push out when the assembly is loosened. (Fig. 7a)
- Take out the blade (C), and then the blade lock bar (B).

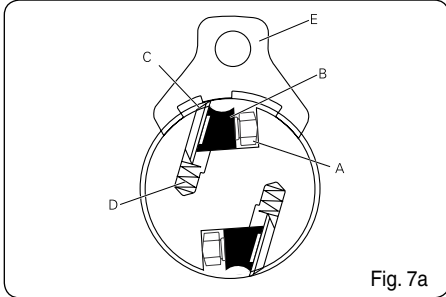

Fig. 7a

INSTALLING THE PLANER BLADES (Fig. 7a)

WARNING:

Unplug your planer from the power source before removing the planer blades.

To install the planer blades, follow the steps outlined below:

- Remove the blades according to the instructions for “REMOVING THE PLANER BLADES”
- Fit the blade lock bar (B) into the slot on the cutterhead.
- Fit the blade into the slot on the cutterhead, and tighten the lockbar blade assembly by turning the screws counter clockwise. Make sure the blade is facing the correct direction.
- Set the blade heights according to the instructions as shown below. The blade height must be reset every time the blades are taken out for any reason.
- Be sure to replace the chip guard after blades are installed.

SETTING THE BLADE HEIGHT (Fig. 8&8a)

- To obtain a blade projection of 1.5mm, place the blade setting gauge (E) on the cutterhead with both guides resting firmly against the blade. (Fig. 8)
- Loosen the assembly by turning the 7 screws (A) clockwise with an open end wrench.
- When the blade is pressed to the required height by guides on the gauge, retighten the assembly by turning the screws counter clockwise. Make sure all seven lock screws are tightened securely.

WARNING:

The blade edge is very susceptible to chipping. Use caution when handling the gauge near the blades to avoid damaging them.

WARNING:

The assembly must be tightened securely to prevent accidents during planing.

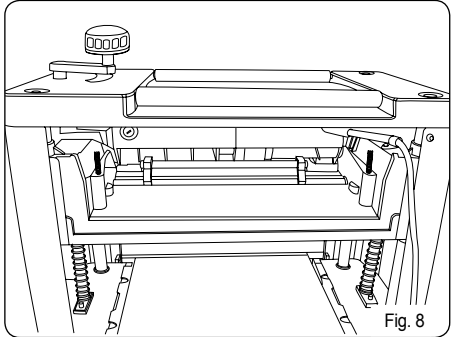

Fig. 8

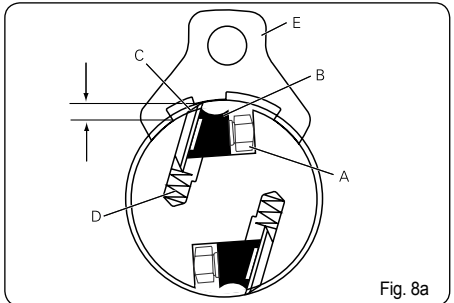

Fig. 8a

MAKING THE CUTTERHEAD AND WORKTABLE PARALLEL (Fig. 9~12)

Plane a workpiece and measure thickness after the cut. If the thickness is not the same on both sides of the workpiece, perform the following action.

Adjust the cutter shaft and the worktable so they are parallel. The tools used for checking are shown below. Please use hardwood to make a tool gauge block according to the size shown in the figure 9. Make the adjustments as per the following procedures.

- Remove height adjustment handle and both top and side covers by removing allen screws (Fig.11) to expose height adjustment lock nuts. (Fig.12)
- Loosen adjustment lock nut. (Fig.12)
- Adjust height nut up or down as required to suit gauge block. (Fig.10)
- When desired height setting is reached, tighten lock nuts in position. (Fig.12)
- Reassemble side and top covers and replace height adjustment handle.

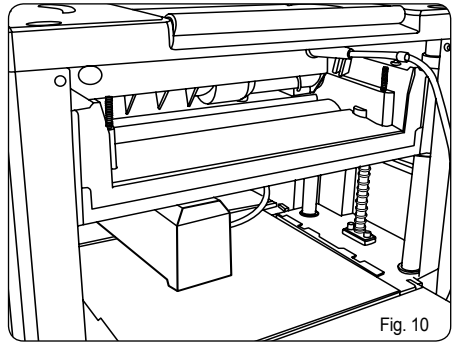

Fig. 10

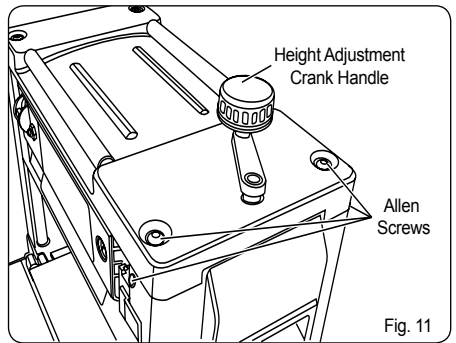

Fig. 11

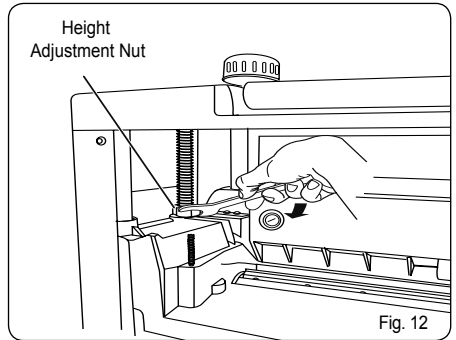

Fig. 12

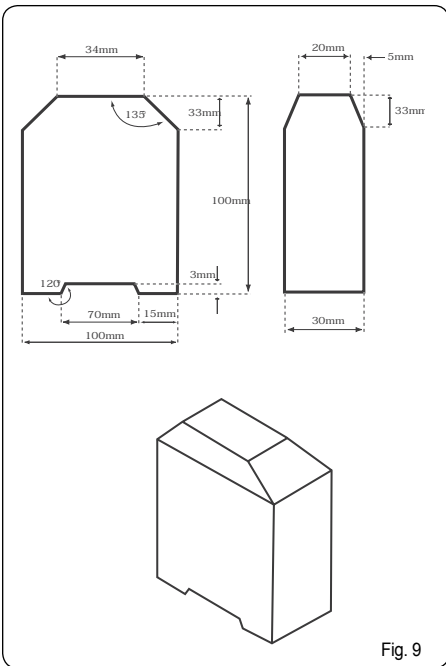

Fig. 9

NOTE: Remove gauge block before starting machine.

Thickness planing is the sizing of the material to a desired thickness, while creating a smooth surface parallel to the opposite side of the board.

The art of thickness planing consists mainly of using good judgement about the depth of cut in various situations. You must take into account:

- 1) The width of the timber
- 2) The hardness of the board
- 3) The dampness of the board
- 4) The straightness of the board
- 5) The grain direction
- 6) The grain structure

How these factors can effect the quality of the work can only be learned through experience. Whenever working with a new type of wood, or one with unusual problems, always make test cuts on scrap material prior to working on the actual piece.

FOR ADDITIONAL PLANING

If additional planing is needed to obtain the desired thickness or finish, hand crank the cutterhead no more than 3mm (at any one time) and complete another pass.

WARNING:

Never plane more than 3mm in one pass and never attempt to plane a board under 127mm (5") in length. Always wear a protective face shield.

INSTALLING THE DUST CHUTE

- Currently, the planer is assembled with a steel cover , which is fixed by 2 wing nuts (Fig. 13 & 13a)

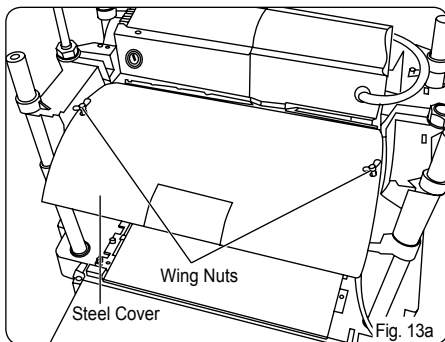

- To install the dust chute , remove the steel cover first by unscrewing the 2 wing nuts.
- Fix the dust chute with 4 philip screws (Fig 13b)

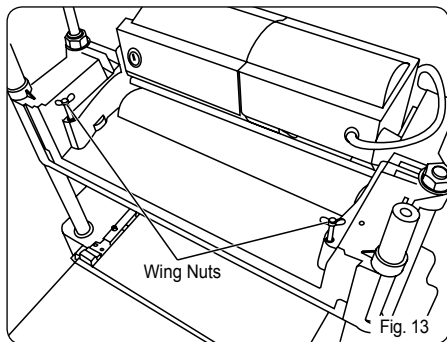
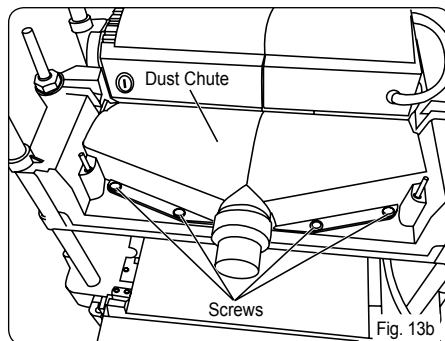

LUBRICATION

- The recommended lubrication for roller chains used in medium to low operation is to simply wipe the chain clean. When there is an excess build up of dust or wood shavings etc., coat chain with a light film of oil but never pour the oil directly on the chain. Over-oiling tends to hasten the collection of dust and woodshavings and works them into members of the chain leading to increased wear and premature replacement. This applies to the speed reduction and height adjustment chains as well as the elevation screws.
- The bearings on the cutterhead are factory lubricated and sealed. They require no further attention.

PERIODIC MAINTENANCE

- Build-up of sawdust and other debris can cause your machine to plane inaccurately. Periodic cleaning is mandatory for precision planing and highly recommended.
- Close fitting parts, such as the lockbars and the planer cutterhead slots, should be cleaned with a brush; removing clinging foreign matter. Then replace all parts in their respective positions slightly dampened with oil.
- Remove resin and other accumulations from feed rollers and table with a non-flammable solvent.

TROUBLESHOOTING

PROBLEM	POSSIBLE CAUSE	REMEDY
FUZZY GRAIN	<ol style="list-style-type: none"> 1. Planing wood with high moisture content. 2. Dull Blades. 	<ol style="list-style-type: none"> 1. Dry the wood 2. Sharpen Blades.
TORN GRAIN	<ol style="list-style-type: none"> 1. Too heavy a cut. 2. Blades cutting against the grain. 3. Dull Blades. 	<ol style="list-style-type: none"> 1. Review proper depth of cut 2. Feed wood with the grain, or turn workpiece around. 3. Sharpen Blades.
ROUGH / RAISED GRAIN	<ol style="list-style-type: none"> 1. Dull Blades. 2. Tool heavy a cut. 3. Moisture content too high 4. Cutterhead bearings damages. 	<ol style="list-style-type: none"> 1. Sharpen Blades. 2. Review proper depth of cut 3. Dry the wood. 4. Replace bearings.
UNEVEN DEPTH OF CUT SIDE TO SIDE	<ol style="list-style-type: none"> 1. Blade projection not uniform. 2. Cutterhead not levelled to planer bed. 	<ol style="list-style-type: none"> 1. Adjust Blade projection. 2. Level cutterhead to table.
BOARD THICKNESS DOESN'T MATCH DEPTH OF CUT SCALE	<ol style="list-style-type: none"> 1. Depth of cut scale incorrect. 	<ol style="list-style-type: none"> 1. Adjust depth of cut scale.
CHAIN JUMPING	<ol style="list-style-type: none"> 1. Sprockets misaligned. 2. Sprockets worn. 	<ol style="list-style-type: none"> 1. Align sprockets. 2. Replace sprockets.
MACHINE WON'T START / RESTART	<ol style="list-style-type: none"> 1. Not plugged in. 2. Circuit breaker / fuse. 3. Motor failure. 4. Loose wire. 5. Overload reset has not reset. 6. Motor starter failure. 	<ol style="list-style-type: none"> 1. Check power source. 2. Check power source. 3. Have motor checked. 4. Have motor checked by authorised Ryobi service agent. 5. Allow machine to cool down and restart. 6. Have motor starter checked by authorised Ryobi service agent.
REPEATED CIRCUIT TRIPPING RESULTING IN MOTOR STOPPAGE	<ol style="list-style-type: none"> 1. Extension cord too long or too thin. 2. Blades too dull. 3. Low voltage running. 	<ol style="list-style-type: none"> 1. Use a shorter or thicker extension cord. 2. Sharpen or replace Blades. 3. Check voltage.
POOR FEEDING OF TIMBER	<ol style="list-style-type: none"> 1. Planer table dirty. 2. Feed roller damaged 3. Sprocket damaged. 4. Gear box malfunction. 	<ol style="list-style-type: none"> 1. Clean off pitch and residue, and lubricate planer table. 2. Replace. 3. Replace. 4. Check gear box.
WORKPIECE JAMMED	<ol style="list-style-type: none"> 1. Inadequate Blade setting height. 	<ol style="list-style-type: none"> 1. Set the Blade to the correct height.

RYOBI TECHNOLOGIES AUSTRALIA PTY. LTD.

GUARANTEE



Subject to the guarantee condition below, this Ryobi tool (hereinafter called "the product") is guaranteed by Ryobi (hereinafter called "the Company") to be free from defects in material or workmanship for a period of 24 months from the date of original purchase covering both parts and labour. Under the terms of this guarantee, the replacement shall be the opinion of the Company or its authorised agent. Should service become necessary during the warranty period, the owner should contact the RYOBI HELPLINE 1300 361505, or the Ryobi retailer from where the product was purchased. In order to obtain guarantee service, the owner must present the sales docket and Guarantee Certificate to confirm date of purchase. This product is sold by the dealer or agent as principal and the dealer has no authority from the Company to give any additional guarantee on the Company's behalf except as herein contained or herein referred to.

failure resulting from misuse, neglect, abuse, or used for a purpose for which it was not designed or is not suited and no repairs, alterations or modifications have been attempted by other than an Authorised Service Agent. This guarantee will not apply if the tool is damaged by accident or if repairs arise from normal wear and tear.

The Company accepts no additional liability pursuant to this guarantee for the costs of travelling or transportation of the Product or parts to and from the service dealer or agent - such costs are not included in this guarantee.

Certain legislation, including the Trade Practices Act, 1974 (as amended) and other state and territorial laws give rights to the buyer and impose liability on the seller in certain circumstances. Nothing herein shall have the effect of excluding, restricting or modifying any condition, guarantee, right or liability imposed, to the extent only that such exclusion, restriction or modification would render any term herein void.

Guarantee Conditions

This guarantee only applies provided that the Product has been used in accordance with the manufacturer's recommendations under normal use and reasonable care (in the opinion of the Company) and such guarantee does not cover damage, malfunction or

RYOBI

RYOBI TECHNOLOGIES AUSTRALIA PTY. LTD.

A.B.N. 98 002 277 509

SYDNEY: 359-361 Horsley Road, Milperra, N.S.W. 2214.

Contact during normal business hours.

Tel: (02) 9792 9800 - Fax: 1800 807 993 - www.ryobi.com.au

BRISBANE:

All enquiries Tel : 1300 361 505

TOWNSVILLE:

All enquiries Tel : 1300 361 505

MELBOURNE:

960 Stud Road, Rowville, Vic. 3178

Tel : (03) 9764 8656

HOBART:

All enquiries Tel : 1300 361 505

ADELAIDE:

All enquiries Tel : 1300 361 505

PERTH:

33-35 Sorbonne Cres., Canning Vale, W.A. 6155.

Tel : (08) 9455 7775

RYOBI NEW ZEALAND PTY. LTD.

AUCKLAND: 27 Clemow Drive, Mt Wellington, N.Z.

Tel: (09) 573 0230 - Free Call: 0800 279 624 - Fax: (09) 573 0231 - www.ryobi.co.nz

Contact during normal business hours.

This Guarantee Form Should Be Retained By The Customer At All Times

For your record and to assist in establishing date of purchase (necessary for in-guarantee service) please keep your purchase docket and this form completed with the following particulars.

Purchased From _____

Address Of Dealer _____

Date _____ Model No _____ Serial No _____

Present This Form With Your Purchase Docket When Guarantee Service Is Required.